



Mestrado Integrado em Engenharia Electrotécnica
e de Computadores

**Linear and Nonlinear State-Space Control
Theory / Controlo em Espaço de Estados**

Problems for the Practice Classes

J. Miranda Lemos

Fevereiro de 2013

Translated to English by José Gaspar, 2016



P1. (*State-space model building from fundamental equations of physics, chemistry, etc*) Obtain the equations of a linear state-space model for the circuit of fig.1. Use as state variables the voltages of the two capacitors with respect to the reference (ground) node, use as input variable the current source and use as output variable the voltage at the terminals of the resistor on the right.

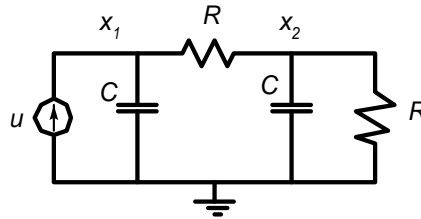

Fig. 1 – problem P1.

Obtain another (any one) state-space model that corresponds to the same transfer function.



P2. (*State-space model building from fundamental equations of physics, chemistry, etc*) Consider the mechanical system of fig.2, where u represents a force extra to the weight of the mass (m) and such that at $z=0$ the spring has an elongation that compensates the weight.

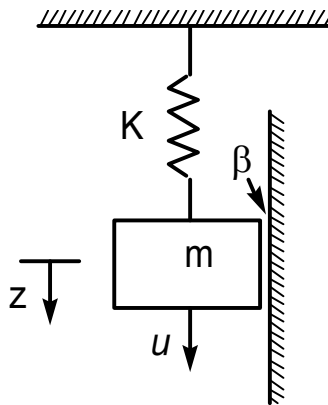

Fig. 2 – Problema P2.

- a) Use Newton's law to obtain the equations of a linear state-space model describing the system. Consider the force u is the input and the position z is the output.
- b) Apply the Laplace transform, considering null initial conditions, to determine the transfer function. Assume $K/m=1$. Consider the case $\beta=0$

and the case $\beta \neq 0$. For each of the cases determine the position of the poles and mark them in the complex plane. Discuss the position of the poles given your intuition about the working of the system.

- c) Consider now that $u = 0$ (autonomous system). Mark one arrow for each of the points of the state plane shown in fig.3 given the signals of the derivatives of the state variables. The arrow indicates the direction that the state will follow starting at each point. Compare with your intuition about the working of the system.

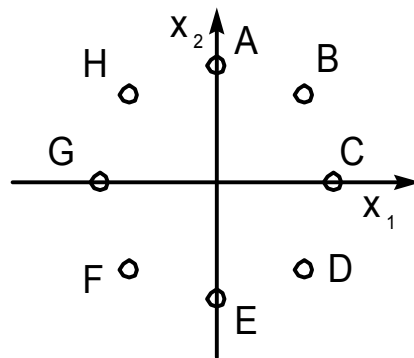

Fig. 3 – Problema P3.

P3. (Converting models) Obtain the transfer function of the system described by the state-space equations:

$$\begin{bmatrix} \dot{x}_1 \\ \dot{x}_2 \end{bmatrix} = \begin{bmatrix} -5 & -1 \\ 3 & -1 \end{bmatrix} \begin{bmatrix} x_1 \\ x_2 \end{bmatrix} + \begin{bmatrix} 1 \\ 1 \end{bmatrix} u$$

$$y = \begin{bmatrix} 1 & 2 \end{bmatrix} \begin{bmatrix} x_1 \\ x_2 \end{bmatrix}$$

P4. (Converting models) Obtain a state description with minimum order of a system with transfer function:

$$G(s) = \frac{2}{(s+1)(s+2)}$$

Modify the realization just done to obtain one state-space model for the transfer function:

$$G(s) = \frac{2(s+3)}{(s+1)(s+2)}$$

P5. (*Solution of the state-space equation of an autonomous system*) Consider once more the mass-spring-dumper system of problem P2. Determine the eigenvalues of the dynamics matrix of the state space model. Then solve the state space equations using a modal decomposition. Compare the solution with your intuition about the way the system works.

P6. (*Calculation of the transition matrix*) Consider the homogeneous state space models whose dynamic matrices are given by:

$$A = \begin{bmatrix} 1 & 1 \\ 4 & 1 \end{bmatrix} \quad A = \begin{bmatrix} 0 & 1 \\ -1 & -3 \end{bmatrix} \quad A = \begin{bmatrix} 0 & 1 \\ 1 & 0 \end{bmatrix}$$

Determine the respective transition matrices, e^{At} , using the following methods:

- Similarity transformation (diagonalization);
- Laplace transform;

P7. (*Controllability and observability*) Consider the system described by the state-space model:

$$\begin{bmatrix} \dot{x}_1(t) \\ \dot{x}_2(t) \end{bmatrix} = \begin{bmatrix} 0 & 1 \\ -\alpha & 1 \end{bmatrix} \begin{bmatrix} x_1(t) \\ x_2(t) \end{bmatrix} + \begin{bmatrix} 0 \\ \beta \end{bmatrix} u(t)$$

$$y(t) = \begin{bmatrix} 1 & \gamma \end{bmatrix} \begin{bmatrix} x_1(t) \\ x_2(t) \end{bmatrix}$$

Indicate for which values of the parameters α , β e γ this state-space realization is:

- Controllable
- Observable

Give one interpretation of the results based in the transfer function.

P8. (*Pole Placement / Full State Feedback - FSF / "Realimentação Linear de Variáveis de Estado - RLVE"*) Consider the system with transfer function

$$G(s) = \frac{s+a}{s(s+1)} \quad a \text{ constant for each case}$$

- a) Obtain a state space representation for the second order system $G(s)$. Name the state variables x_1 and x_2 .
- b) Considering the state variables x_1 and x_2 , indicate the values for the parameter a which allow arbitrarily placing the poles of the closed loop system, by using linear feedback of all state variables (FSF / RLVE). Do not compute explicitly the characteristic polynomial of the closed loop system.
- c) Let $a = 2$. Find the FSF (RLVE) gains such that the closed loop poles are placed in $-4 \pm j$. Assume in this question that you have access to the direct measurement of x_1 and x_2 .
- d) Assume now that you do not have direct measurement of x_1 and x_2 . Indicate values of a such that the system satisfies the condition of being possible to design an asymptotic state observer such that the estimated state error converges to zero as fast as desired.
- e) Let $a = 2$. Write the equations of an observer and design its gains such that the error in the estimated state converges to zero, with eigenvalues $-10 \pm j$ in the error dynamics.



P9. (*Full State Feedback*) In this problem we want to design a controller for a permanent-magnet motor with transfer function

$$G(s) = \frac{10}{s(s+1)}$$

where the input is the voltage applied to the rotor and the output is the angular position of the motor shaft.

- a) Write the state space equation using as state the angular position and spinning speed of the motor shaft.

- b) Compute the gains of a full state feedback control law (FSF / RLVE) such that they place the poles of the closed-loop system as the poles of a second order system with $\omega_n=3$, $\zeta=0.5$.
- c) Compute the gains of a state estimator such that the characteristic equation of the state estimation error dynamics has $\omega_n=15$, $\zeta=0.5$.
- d) What is the transfer function of the controller obtained after solving b) and c)?



P10. (Full State Feedback / RLVE; including an integral effect for precise tracking of references) Consider the system described by the state space model

$$\frac{d}{dt}Ax + Bu, \quad y = Cx$$

$$A = \begin{bmatrix} -1 & 0 \\ 0 & -2 \end{bmatrix}, \quad B = \begin{bmatrix} 1 \\ 1 \end{bmatrix}, \quad C = [1 \quad 3]$$

- a) Let $u = -Kx + Nr$. Find a vector K such that the closed loop system has the eigenvalues placed at $-2 \pm 2j$.
- b) Compute N such that if $r=r_\infty$ constant then $y=y_\infty=r_\infty$, i.e. the static position error is null. Show that this property (null static position error) is not robust to changes in matrix A .
- c) Add an integrator to the system

$$\frac{d}{dt}\eta = e = y - r$$

and choose the gains K and k_i , such that if $u = -[K, k_i][x, \eta]'$ then the eigenvalues of the closed loop are placed at $-2, -1 \pm 3^{1/2}j$. Show that in this case the system has null static position error, and that this property is robust to changes in matrix A , provided that the closed loop system remains stable.



P11. (Nonlinear systems: relationship between nonlinear dynamics and dynamics linearized at equilibrium points)

There were recently discovered two new species of herbivorous, nicely named Necs and Plaks, living in the Melanesia island. A number of biological studies have shown that the two species compete for the same food and the mean numbers of the populations can be modeled by a system of nonlinear differential equations:

$$\begin{cases} \frac{dN}{dt} = N(1 - N - P) \\ \frac{dP}{dt} = P\left(\frac{1}{2} - \frac{1}{4}P - \frac{3}{4}N\right) \end{cases}$$

where N is the number of Necs and P is the number of Plaks. These numbers are normalized. More in detail, one has to multiply the numbers by 1000 to obtain the real numbers of the populations. Given the model just introduced, determine if the two populations can coexist in the long term.

Suggestion: Start by showing that $N = \frac{1}{2}$, $P = \frac{1}{2}$ is an equilibrium point of the nonlinear system and study what happens to the populations if this equilibrium is slightly disturbed.



P12. Consider the autonomous system (i.e. a system without inputs), of second order, described by the system of nonlinear equations:

$$\begin{aligned} \frac{dx_1}{dt} &= -x_2 - x_1(x_1^2 + x_2^2) \\ \frac{dx_2}{dt} &= x_1 - x_2(x_1^2 + x_2^2) \end{aligned}$$

a) Show that the origin is an equilibrium point of the system. Obtain the equations of the system linearized around the origin. Classify the origin in

terms of the eigenvalues of the linearized system. Say what you can conclude about the behavior of the nonlinear system around the origin.

- b) Using the Lyapunov's 2nd method, and considering the Lyapunov candidate function $V(x_1, x_2) = \frac{1}{2}(x_1^2 + x_2^2)$, what can you tell about the origin of the nonlinear system?



P13. Consider the 2nd order nonlinear system, without inputs, described by the state space equations:

$$\begin{aligned}\frac{dx_1}{dt} &= -2x_1^3 + 4x_2^3 \\ \frac{dx_2}{dt} &= -4x_1x_2^2\end{aligned}$$

- a) Considering Lyapunov's 2nd method and using the Lyapunov candidate function

$$V(x_1, x_2) = \frac{1}{2}(x_1^2 + x_2^2)$$

show that the origin ($x_1 = 0, x_2 = 0$) is an equilibrium point, which is stable, at least in the sense of Lyapunov. Say if you can guarantee that the point is asymptotically stable.

- b) Using the Invariant Set Theorem show that the origin is effectively asymptotically stable.



P14. Consider the system of fig.4 where the tank input flow, "caudal" in Portuguese, $u(t)$ is controlled in order to regulate the level $h(t)$ to a reference level r constant and known. Assume that all horizontal sections of the tank have the same constant value A , which is known. Assume $A = 1$. The area of the output opening at the tank base is described by a , and has an unknown value. The dynamic of the level of the tank is described by

$$A \frac{dh}{dt} = u - \theta \sqrt{h}$$

where θ is a parameter to estimate.

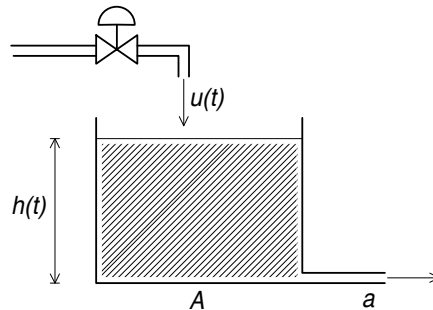

Fig. 4 – Problem P14.

- Assuming a perfect knowledge of θ , determine a static feedback of the system output such that the system (tank + feedback) behaves like an integrator.
- Still assuming perfect knowledge of θ , apply a linear control law to the resulting integrator such that the following error $e(t) = h(t) - r$ of the controlled system converges to zero with a time constant of 2 seconds.
- Using the Lyapunov's 2nd Method, obtain a control law adjusting the parameter θ which guarantees the complete system is stable.

Say, in a justified manner, whether or not can be guaranteed the following error $e(t) = h(t) - r$ tends to zero as t tends to infinity.



P15. The company *Confeitaria Rainha Regional*, well known since 1890, makes the delicious and well know flour *Farinha Integral 33*, essential for the many nutritious breakfasts of the greatest engineering schools, is studying the optimal investment policy in one of its production lines. After thoroughly studies by the company managers, has been concluded that the production, P , has a relationship with the investment I (time varying) given by the model:

$$\frac{dP}{dt} = -0.1P + 0.5I \quad P(0) = 1$$

where the time unit is 1 year.

The production line is expected to operate 15 years, and after that will be sold by a price proportional to the production at that time. The total value of the production line is therefore:

$$J = P(15) + \int_0^{15} [P(t) - I(t)] dt$$

The investment is positive and cannot exceed the maximal value I_{\max} , i.e.:

$$0 \leq I(t) \leq I_{\max}$$

Using the Maximum Principle, determine the optimal investment policy $I(t)$, that maximizes J for $0 \leq t \leq 15$.

Helping formulae:

$$\frac{dx}{dt} = f(x, u)$$

$$J(u) = \Psi(x(T)) + \int_0^T L(x, u) dt$$

$$-\left(\frac{d\lambda}{dt}\right)' = \lambda'(t) f_x(x(t), u(t)) + L_x(x(t), u(t))$$

$$\lambda'(T) = \Psi_x(x) \Big|_{x=x(T)}$$

$$H(\lambda, x, u) = \lambda' f(x, u) + L(x, u)$$

Some more help:

The solution of the differential equation:

$$\dot{x}(t) + ax(t) = b$$

where a and b are constants, is given by

$$x(t) = \frac{b}{a} + ce^{-at}$$

where c is a constant that depends on the initial conditions.



P16. Consider the system represented in figure 1 in which one wants to stop a ball rolling in a track, "calha", by applying a voltage to a DC motor.

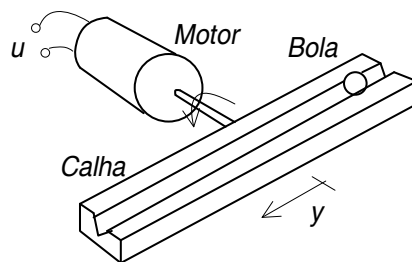

Fig. 1 – Problem P2. Equilibrium of a ball on a track.

Using simplifying hypothesis, the system can be approximated by a model based in a transfer function with two poles at the origin:

$$G(s) = \frac{1}{s^2}$$

Using Chang-Letov's theorem, determine the position of the poles of the closed loop system that optimizes:

$$J = \int_0^{\infty} \left[y^2(t) + \frac{1}{16} u^2(t) \right] dt$$

