

Design and Assembly of a Ground Control Station for Long Range and Long Endurance UAVs

Nelson Teixeira Cavaco
nelson.cavaco@tecnico.ulisboa.pt

Instituto Superior Técnico, Universidade de Lisboa, Portugal

November 2022

Abstract

The increasing number of applications for unmanned aerial vehicles demands reliable and robustness systems that can meet the requirements of a wide range of missions. Having fully operational ground control station that provides reliability, an easy setup, safety, adaptability, easy decision making, among others, is a key point for the success of any unmanned aerial system mission. Therefore, the design and assembly of a ground control station for long range and long endurance unmanned aerial vehicles is presented. The mission requirements are derived from civilian surveillance applications, such as forest, coast or border patrol. The main steps of the design and assembly are covered as well as the description of each system and component and how they operate together to comprise a ground station. The feasibility of a low cost mobile ground control station for missions up to 8h and 100km range is demonstrated.

Keywords: Mobile station, system architecture, flight control, communication, data recording, fail-safe systems.

1. Introduction

UAS technologies are important in several applications not only in military but also in civilian. Whether it is wildfire monitoring, Good transportation, Sea Patrol or even for farming applications UAS play an important role in the future of civilization as we know it.

The importance of having a Control Ground Station, a key part of UAS which enables the safety operation of UAV long endurance missions is clear. This work comes in the follow up of the work done by Afonso Rodrigues in [1], Luís Candido [2], Tiago Ferreira [3], Joana Sousa [4], Alexandre Duarte [5] and Luís Freitas [6] where across several years they studied and implemented a solution for a Long Endurance Electric UAV. LEEUAV is a prototype of 4.5 meters wingspan and ultralight structure with solar panels incorporated that enables the aircraft to fly on missions up to 8h.

In this paper it is conceived and implemented a solution for such GCS capable of operating an UAV over 100km during at least 8h taking in to account several key requirements such as human interfacing, servicing, durability, redundancy and reliability, compliance, mission planning, setup time, platform security, decision making, environmental conditions and crew training.

The result is a GCS in the form of a mobile

trailer capable of operating an UAV safely at distance. Since it is used Mission Planner, the GCS has the ability to control other unmanned vehicles beyond UAV's. For instance RC cars, RC boats or even submarines. Mission planner is an open source software which is prepared for such modularity depending of the needs of the user. It's user interface is very user friendly and uses the MAVLINK communication protocol which enables the secure connection between GCS and vehicle preventing hacker attacks. It exchanges all the important telemetry data as well as the battery state, RSSI and even video. This way analogic video is no longer necessary increasing remote image quality which can be processed and used to do object detection.

To summarize the GCS implemented in this work is the culmination of the community and previous work best achievements resulting in a reliable, functioning, mobile and effortless Ground Control Station to setup and operate at long distances.

2. Unmanned Aerial Systems

Unmanned aircraft system (UAS) means an unmanned aircraft and the equipment to control it remotely.

2.1. Unmanned Aerial Vehicles

The vehicle in order to perform unmanned maneuvers shall incorporate many sensors, as described in

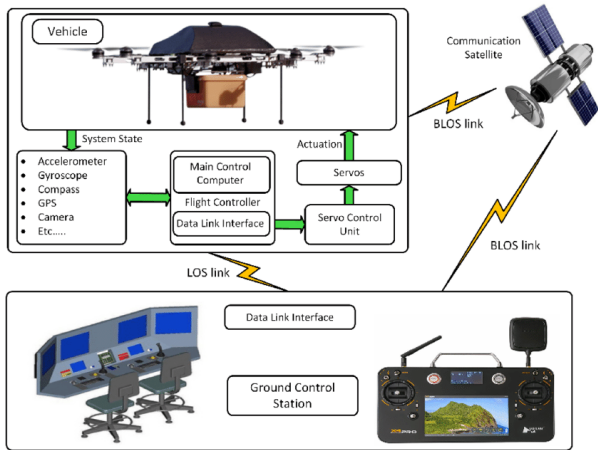

Figure 1: Unmanned Aerial System [7]

Fig.1, to acquire all the data to read and estimate the current state of the aircraft. When a control command is given from the GCS, usually through a radio link between the two, the flight controller compares the command with the current state and generates a signal that is forwarded to the control unit of the actuators. This link can be done directly with just two antennas or behind light of sight with the help of other systems, a satellite for example. On the ground, the command is given by the human interface in the GCS that can be a room full of many features or just a mobile remote control that supports basic operations.

2.2. Ground Control Stations

There are already a wide range of different GCSs but all are conceived taking into account some basic requirements.

While initiating the design of a ground control station, it is important to define the “need to have” and “nice to have” requirements. These are chosen taking into account the operations and missions for which the ground control station will be used and the UAV capabilities controlled by the GCS. In Fig.2, a few aspects([8] and [9]) that shall be taken into account are presented.

2.3. Basic Systems

In terms of connectivity between the UAV and the GCS three interfaces shall be implemented to fulfill three major tasks, as studied in [10].

Therefore the GCS shall be comprised of the following main systems and components which will be described better ahead: flight control, recording, communications and electrical, Fig.3.

3. System and Components

In this section, the GCS systems and components will be scrutinized to its lower level explaining how the systems interact with each other, the electrical

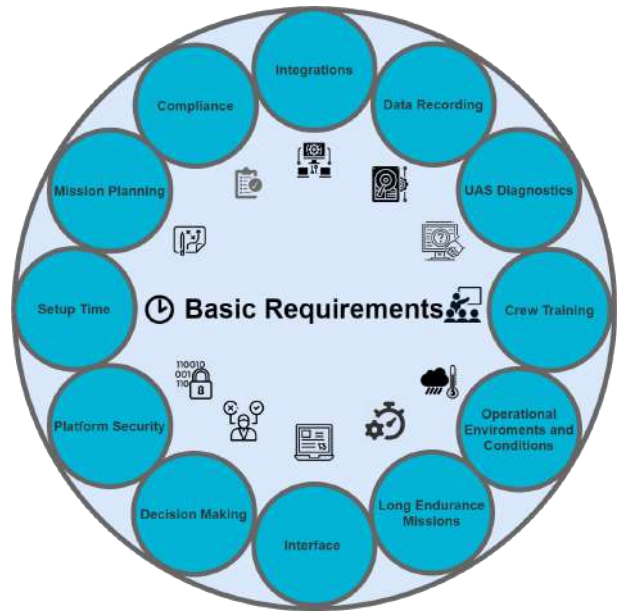

Figure 2: Key basic requirements

connections and its communication protocols with the intention of making it clear how exactly this GCS will be composed of.

3.1. Main Systems

From a general standpoint, we can divide the GCS into four main systems as illustrated in Fig. 3.

3.1.1 Flight Control

The Flight Control system is responsible for the controllability of the aircraft in every stage of autonomous flight, including take-off, climbing, loiter, trajectory following, descent, hold and landing. Through this system, the operator must be able to control, monitor and send commands to the aircraft. This system is composed of: the computer, the screen displays, the Mission Planner software and the radio control.

3.1.2 Communication

There are several methods to send and receive data in UAS. The data exchanged between the GCS and the UAV can be commands, telemetry data or/and video. In order to have that exchange of information, radio frequency transceivers and antennas are used along with communication protocol that makes possible the data transfer and its interpretation. MAVLINK and PPM are just a few.

3.1.3 Data Recording

Data mostly enters the GCS through MAVLINK and via Human Interface. Either way it goes through the computer which has its own memory RAM in



Figure 3: GCS systems and subsystems

which data logs can be created. Managing the data of different flights and missions represents an important factor to the success of the mission. In addition, the analog video receiver system saves its images directly to an SD card. This enables the easiness of taking out the images from the GCS to any other device by simply taking out the SD card from the SD card reader.

3.1.4 Electrical

In order to power up the GCS and all of its systems, electricity shall be fed into the trailer. Power failures are likely to occur and shall be mitigated with redundant components along with a good cable management to ensure reliability. In Fig.4 the power system architecture that will be implemented to ensure redundancy, reliability and control over the different sources. With the implementation of switches, it is possible to control and choose in a manual way what is turned on and what is not.

From an operation point of view, preferably the generator is used as main source of power, having a differential switch satisfying the standards of the International Electrotechnical Commission in order to ensure safety of humans in case of short circuit. Both generator and grid sources have this protection. Then a source selector is added to give the possibility to switch between sources manually and

safely. A double power converter is chosen to emulate an online UPS system.

The power distribution is divided between essential components and non essential components. Having two different working voltages, the distribution is described in Fig.4, as Non Essentials@230VAC, Non Essentials@12VDC, Essentials@230VAC and Essentials@12VDC. This way it is specified what should be turned on during normal operation in case of power failure.

In addition, the operator can, in any instance (before, during or after the mission) be able to disable manually individually each segment through switches A, B and C. They can be turned on and off whenever is necessary.

In case of an eventual malfunctioning or shutdown due to any cause, only essential systems are turned on to maximize the duration of the battery and consequently the operation in course.

3.2. System Architecture

The main systems are :

- Power system - designed to power all systems and had previously explained in Sec.3.1.4 ;
- Communications, antennas and video recording - is the hardware responsible to broadcast and receive, through electromagnetic waves, the commands and telemetry between the GCS

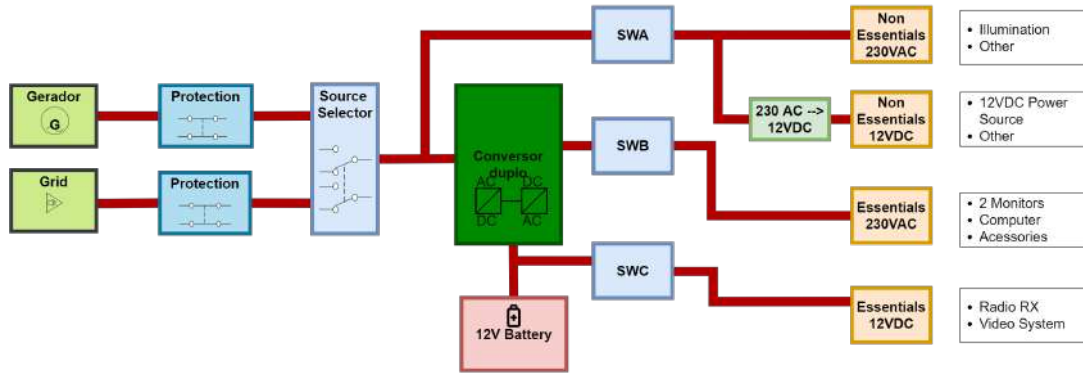

Figure 4: Power System Architecture

and the UAV as well as to receive and record the analog video stream;

- Computer - Runs the Mission Planner and acts like a telemetry recording system;
- RC Controller and Human Interface - where the operator can give inputs to the GCS and control either manually or through actions the UAV.

As the operator uses Mission Planner which runs on the computer, the commands are introduced through mouse and keyboard. These are interpreted by the Mission Planner, encoded into MAVLINK packets and sent over a serial COM port - just a USB cable connected to a USB port - which in turn are received by the RF transmitter and modulated into Frequency shift keying (FSK) modulation. The radio then transmits this analog signal onto the coaxial cable to the antenna which then emits the electromagnetic wave onto the UAV.

For the RC controller, the operator controls the UAV manually giving inputs by simply adjusting the joystick in the controller. The percentage of the movement of the joystick is encoded into PPM packets and sent through the transmitter.

The video System is comprised of a RF receiver and an SD card video recorder. The video image arrives the GCS in format PAL and is then recorded in the SD card.

Every system can be turn on and off independently through the human interface through a central panel which will be explained ahead in this document.

3.3. Electrical Schematic

To begin with, a draft of the necessary interconnections and wiring between the different components and systems was done, Fig.6. While some wiring represent power, other symbolize the flow of data or video stream. From here, more drafts were made to think how spatially everything would fit together inside of the trailer. That is discussed later.

In a succinctly manner energy must flow from the power generator to the double converter. All that is essential and crucial to the success of the mission is powered by the converter to ensure that there is no energy gap, in case of fuel ends up or any other power failure.

The video system requires 12VDC while everything else require 230VAC to work properly. The central indicator and control panel, as the name says will be a set of indicators and control switches to power ON and OFF each one of the systems.

Other connections that are not power connections are the video stream. Since it enters the GCS through the antenna of the video receiver, it flows to the DVR recorded and then is displayed on one of the LCDS. This is the analogical video system.

The commands and telemetry are exchange via another radio. The telemetry radio 3DR is connected through USB to the computer, therefore not needing any kind of power input.

In addition, attached to the computer there will be all the human interface components: mouse, keyboard, microphone and headphones and/or speakers.

Now, to better explain how everything is connected, the electrical schematic is divided into five groups: power supply, computer system, video system, radio system and other.

The central indicator and control panel concept was done. Somewhere in the center of the human interface, a panel of switches capable of turning on and off each system was envisioned.

3.3.1 Power Supply

The networks are divided into four groups: Non Essentials@230VAC, Non Essentials@12VDC, Essentials@230VAC and Essentials@12VDC, each one of them has an associated LED that turns on in the central panel when its associated switch is turned on. Another LED is connected in parallel with the battery to indicate that it is connected and feed-

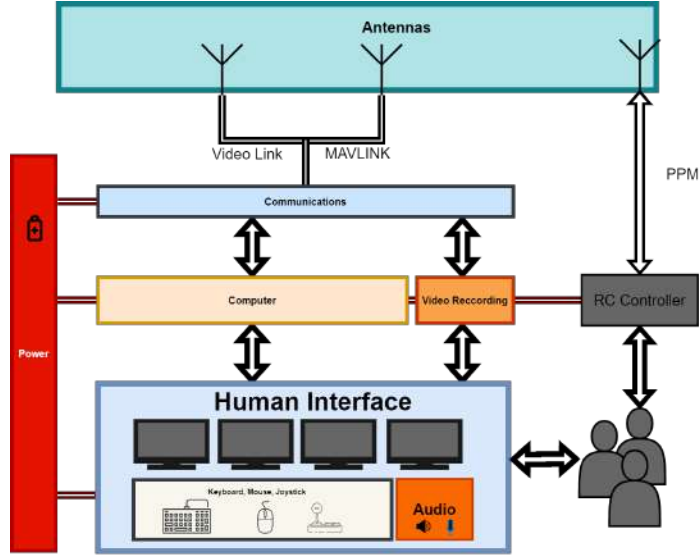

Figure 5: GCS System Architecture

ing the Essentials@12VDC network. A double converter is included in order to continuously feed the Essentials@230VAC network. The rest of the systems are connected to this four main networks.

3.3.2 Computer System

The computer system is comprised of the computer, four screen displays, keyboard and mouse and USB ports. These are all components which are essential for the success of the mission, therefore, they are connected to the Essentials@230VAC grid. Meaning that if any power failure happens, they will stay on.

3.3.3 Video System

The video system is composed of two video receivers, an Oracle Diversity, an SD recorder and a ten inch LCD screen display. All of it is located on the upper central panel as it will be presented later on.

3.3.4 Radio System

The radio system is very simple. Just composed of it self and the antenna to be used. The SMA connector provides the ability to easily connect and disconnect any antenna that suits the operator right at the setup, before the mission.

3.3.5 Other

Here are the lights and all other power plugs located all around the trailer. Since they add ons and are not relevant to the mission they are connected to the Non Essenstials@230VAC power grid.

3.4. Power Budget

In Tab.3.4 Tab.3.4 is summarized the power consumption both for the 230VAC systems and for 12VDC systems, respectively.

As previously said in Sec.3.1.4 the GCS is divided into four different grids. As the generator can provide 2000W, this is the maximum value which cannot e exceeded. For the ESSENTIALS@230VAC there will be four LCD monitors, one computer and all its periferals. Accounting also to a factor of loss, giving a safety margin of 120 Watt, the total power consumption is about 484 W.

Table 1: ESSENTIALS@230VAC systems power consumption

System	Qty	Component	Power [W]
Computer	1	Computer	300
	4	LCD	64
		Loss Factor	120
TOTAL			484

For the ESSENTIALS@12VDC it is considered a loss factor of 10 W. The included systems are the radio and video system. The total power consumption will be about 34 W.

Table 2: ESSENTIALS@12VDC systems power consumption

System	Qty	Component	Power [W]
Radio	2	RF_Module	4
	2	Video_Receiver	6
Video	1	SD_Card_Recorder	3
	1	Monitor_2	10
	1	Oracle Diversity Controller	1.2
		Loss Factor	10
TOTAL			34.2

Taking into account these power consumptions it

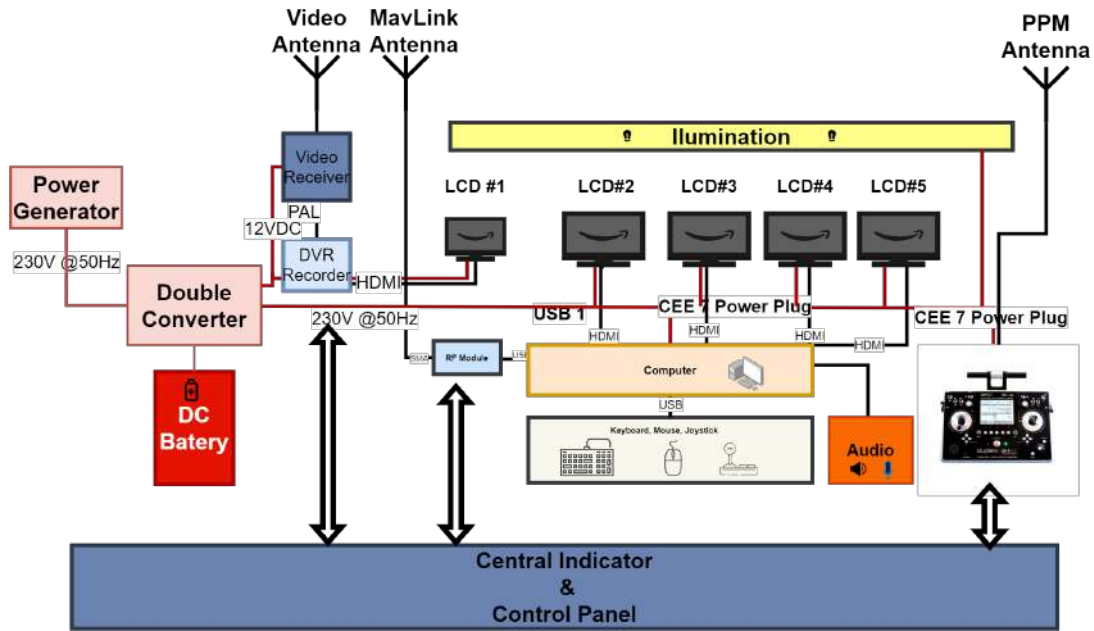

Figure 6: Electrical schematic draft

is now clear that the 2000 W power generator will be enough to power this GCS. The operator can still make use of the extra 1400 W for personal laptops or any other devices that required electric energy.

4. Layout

This section aims to show the conceptual design of the GCS along with its aspects and features in order to operate correctly.

4.1. Overview



Figure 7: Ground Control Station

In Fig.7 is what the GCS should look like when fully assembled and operational.

A power generator is shown connected to the trailer to power up the GCS. One of the two workstations as well the antenna system can be seen in this figure.



Figure 8: Operator Interface

4.2. Operator Interface

The Operator Interface is what exchanges information between the UAS and the Operator. The operator shall be instructed with the manual and procedures list before operating this GCS to prevent any eventual accidents. In Fig.8 it is possible to see the rendered image token from Solidworks CAD software of the human interface panel. Marked with numbers are: 1 – LCD screen display; 2 – Keyboard and mouse; 3 – Central indicator and control panel ; 4 – Analog video system panel.

4.2.1 Electric Central Panel

This where the Hager CDC2250 residual current devices, the Hager SFB225 changeover switch and the Hager SFB225 modular switch are located. This is the central panel for all the 230VAC grids. The energy first comes into here before flowing to the rest of the GCS, therefore, enabling safety and control over the different 230VAC systems.

4.2.2 Central Indicator and Control Panel

The Central indicator and control panel is where the state of the different components is displayed ,Fig.9. Here the operator can know from which source the GCS is being powered from. Furthermore, taking in consideration the definitions of Non Essentials@230VAC, Non Essentials@12VDC, Essentials@230VAC and Essentials@12VDC stipulated in Sec.3.1.4, it can be known the state of this power grids.

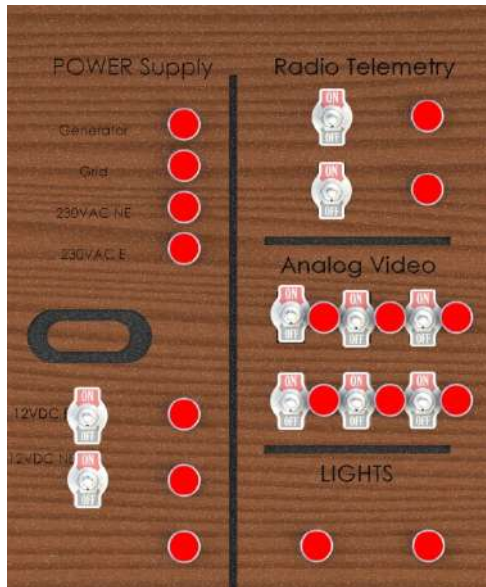

Figure 9: Central Indicator and Control Panel

4.3. Structure



Figure 10: Assembled MDF structure concept model

The human interface panel is where the major components are located. Such components must be well fixed and in case of the LCD, they have to be positioned with a tilt angle. Therefore, a structural assembly that holds the LCDs, the central indicator control panel, the analogical video system was designed and conceived.

The assembly is composed of six pairs of glued MDF profiles as it can be seen in Fig.10(c). Four

big MDF planks go through the six profiles. Two at the center, side by side to ensure structural stability, and two to create the necessary distance and angle for the fixation of the LCDs. This way, the LCD screen position will be easy to adjust and align with its mdf front frame.

Moreover, thinking also on the cable management, the side perspective holes are for that purpose.

4.4. Cable Management

Taking into account all systems and components described in previous sections, Fig.11 describes how spatially they will be connected and positioned.

Around number one will be both generator and grid power inputs. The double converter and battery will be there too. The wiring goes from one to three, where the electric central panel is positioned. The 230VAC switches are there. Furthermore, the illumination LED lights represented as yellow, are also connected between three and two. The intensity regulators will be near number one.

Near number two there is the central indicator and control panel where all the LED indicators are displayed, and consequently, connected between one and three. All the cables are meant to follow technical gutters.

4.4.1 Wiring

For the 230VAC grids, the current flowing through the systems won't go further than 16A. That means that a section of 1.5mm² is enough. For the 12VDC systems, looking at Fig.11 (a), the distance between 1 and 2 is about 3 m. In order to know what should be the wire section area the drop voltage due to the resistance of the cable shall be considered. An online calculator [11] is used to ensure that the voltage drop is about 3%, as recommended. By filling the parameters in the calculator, at 12VDC, 3A, 1.5 mm² section wire and 3 m distance from the load it is concluded that the voltage drop is 2.5% below the required, therefore, meaning that a 1.5mm² section wire is good enough for this application.

5. Implementation

5.1. Structure

As the Aerospace laboratory has a CNC machine, and the use of MDF was evidently a solution for this purpose, the possibilities were many. After some drafts, the final design was done. As the profiles were being manufactured, Fig.12 by the CNC. The fact that this CNC is not the best precision tool, the profiles were not finished yet. After that they were polished either with a drummel tool or with a wood sandpaper, Fig.12.

As the manufacture process was a very time consuming and the quality of the profiles were not the

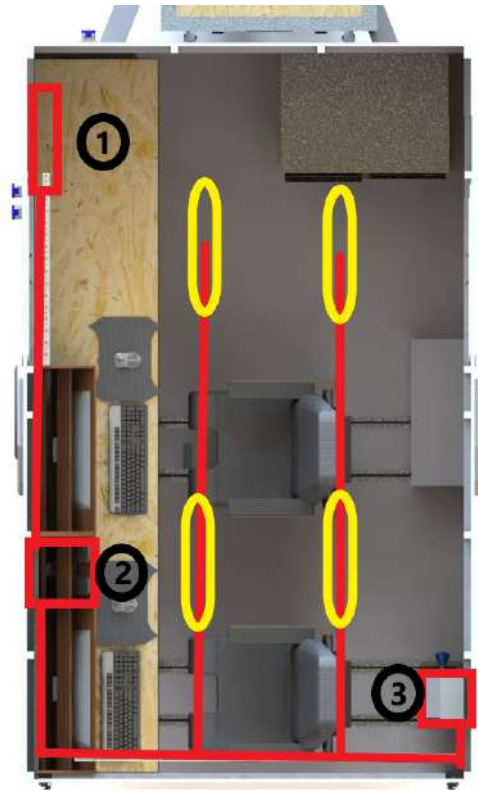

(a) Top view

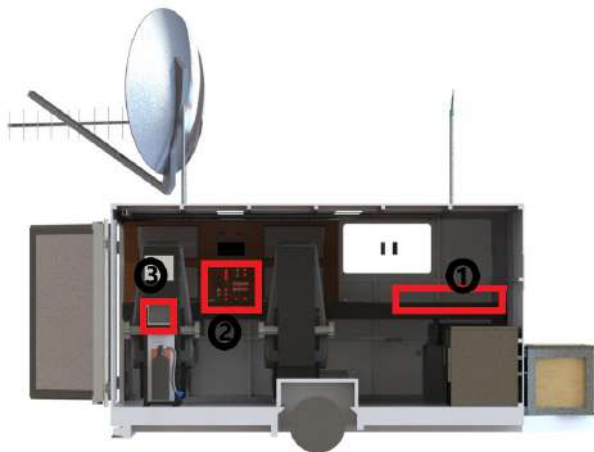

(b) Side view

Figure 11: GCS's cable management draft



Figure 12: IST laboratory CNC machine manufacturing

best due to the CNC machine being old, other solutions were found, namely FalLab Lisboa.

After being manufactured and polished the profiles were glued together to form the "V" shaped supports.



Figure 13: FabLab Lisboa CNC machine manufacturing

At this point all the parts were been manufactured and were ready for the assembly inside the station. The structure was pre assembled outside and then brought inside. The alignment was from left to right, making sure that each part was well fixed with screws and "L" shaped metal plates. After that the technical gutter was fixed along with one CEE.

5.2. Electrical

The electrical board panel was fixed in the first place. The technical gutters all across the area conceived for the wiring placement. Most of the wiring was done at this time. Every time a new connection was done, a subsequently test was performed right after. This was a good way to know that the thing were running as supposed.

The double converter was connected to station. This enabled the possibility of having the LED lights as well connected and their respective intensity regulators. For safety reasons, this required the fixation of the battery connectors. The short circuit risk was minimized by screwing them to the plastic technical gutter. With this all the 12VDC wires were connected.

The central indicator and control panel, that was previously assembled with all those switches and LED indicators, is also connected to the station and tested right after, Fig.14.

At this time two of the monitors have been fixed along with their respective wiring connections. The fixation was done using a standard LCD screen holder with two screws on one of the diagonal planks.

In addition, a small hatch was done in the existent wooden frame right at the center of the two working stations.

5.2.1 Electrical Board and Central Panels



(a) Eletric board panel



(b) Central Indicator and Control Panel

Figure 14: Electrical board and central panels

Taking a closer look at the electrical board panel, the Fig.14(a) shows both residual current devices on the left. At the center is the source selector. And finally, at the right just two simple 16A switches for the NONESSENTIALS@230 and ESSENTIALS@230, respectively.

In Fig.14(b) is the central indicator and control panel. The video system with Both video receivers, the FPV monitor and the SD card recorder are also above this panel as shown in Fig.15.

5.3. Final Assembly and Basic Testing

With everything working and running, some tests were performed on spot.

The video stream was tested. The images appeared to be clear as it can be seen in Fig.14(b). For the MAVLINK connection, there was a similiar test. With a pixhawk and the radios 3DR Robotics a flight was simulated. By opening the Mission Planner on the desktop computer, the connection was done in less then one minute and runned smoothly during all the time. The video stream kept running and recorded in the SD card during this time. In Fig.15 it is possible to see the GCS running with the Mission Planner opened on the top left screen.

For the PPM there was no test performed.



Figure 16: GCS with the assembled antennas

In Fig.16 the GCS and the antennas on top can be seen. Since the testing was perform inside the LAB, these antennas were positioned, but not used for these tests. These antennas are recommended for long range missions only.

6. Conclusions

A fully operational and versatile GCS for long range and Long endurance UAVs was assembled.

This GCS has numerous strengths. The fact that it can be about eight hours running with the insurance that it will never run out of energy during operations is a key aspect in any UAS operation.

In addition, the fact of being a mobile GCS gives it another plus. As the mission can be anywhere, this creates possibilities that other ground stations won't have. The fact, that there is enough space for at least three person inside, is very useful too. This way, during an unexpected mission, the setup is very easy and fast with a crew of five. While two people – mechanic and the pilot – got to put the UAV on the air manually, there are two GCS's operators setting up the systems and the leader plans the mission, both inside the station. Once the UAV is airborne the main operator assumes control of the aircraft and starts sending it commands trough mission planner.

Finally, many concepts were learned by imple-



Figure 15: GCS running

menting this work. Many soft and hard skills too. During research, a general idea for the working principle of UAS was formed. Taking requirements, transform them into design, assemble and test them is the art of system engineering which was applied here in this work too.

Now this GCS can have multi applications. Either for the projects such like LEEUAV or any other project such like submarines, rc cars or even a rocket GCS.

The main innovative idea in this work was the design of the support. It gives a clean "v" shaped format, giving the possibility to fix the LCD screens with a desired angle and distance from the surface. Also giving the comfort of clean space in the outside while racking all the wires and supports on the inside.

References

- [1] Afonso Santos Rodrigues. Airframe assembly, systems integration and flight testing of a long endurance electric UAV. Master's thesis, Universidade da Beira Interior (UBI), February 2017.
- [2] Luís Cândido. Projeto de um uav solar de grande autonomia. Master's thesis, Universidade da Beira Interior(UBI), 2014.
- [3] Tiago Ferreira. Hybrid propulsion system of a long endurance electric UAV. Master's thesis, Instituto Superior Técnico (IST), 2014.
- [4] Joana Sousa. Solar system for a long endurance electric uav. Master's thesis, Universidade da Beira Interior(UBI), 2015.
- [5] Alexandre Duarte. Development part of the structure of a long endurance electric UAV. Master's thesis, Universidade da Beira Interior(UBI), 2016.
- [6] Luís Freitas. Aerodynamic analysis of a forward-backward facing step pair on the upper surface of a low-speed airfoil. Master's thesis, Universidade da Beira Interior(UBI), 2017.
- [7] Riham Altawy. Security, privacy, and safety aspects of civilian drones: A survey. *ACM Transactions on Cyber-Physical Systems*, 1:1–25, 11 2016.
- [8] ABUL KALAM KHAN. Ground control station, functional requirements. <https://khandronesorigin.com/2016/11/23/ground-control-station-functional-requirements/>, 2016.
- [9] UXV Technologies. Things to consider before purchasing a ground control station. <https://www.uvxtechnologies.com/ground-control-stations/guide-to-choosing-a-ground-control-station-gcs/>, 2016.
- [10] Mladjan Jovanovic and Dusan Starcevic. Software architecture for ground control station for unmanned aerial vehicle. In *Tenth International Conference on Computer Modeling and Simulation (uksim 2008)*, pages 284–288, 2008.
- [11] jCalcnet. Ac and dc voltage drop calculator asnz 3008. <https://www.jcalc.net/voltage-drop-calculator-as3008>.